

# CHURCHYARD REGULATIONS 2015 (memorial tables amended 2022)

Regulations issued under the authority of

Robin Hopkins

Commissary General of the City and Diocese of Canterbury  
in consultation with the Diocesan Advisory Committee

1. No object may be introduced into the churchyard without the written permission of the Minister in accordance with Regulations 3, 4 or 5 or of the Commissary General of the Diocese.
2. No burial, interment or memorial is permitted within four metres of any exterior wall of a church.
3. This Regulation concerns burials. The Minister may grant permission for the introduction into a churchyard of a memorial provided that the following conditions are met:
  - (a) application for the introduction of the object is made in writing to the Minister on the standard "Application under Churchyard Regulations" form, such application to be submitted to the Minister at his or her usual address *and*
  - (b) application is made no sooner than six months after the date of the relevant burial *and*
  - (c) a memorial is in the form of a stone or wooden cross or headstone at the head of a grave and meets the requirements of paragraphs (d) to (o) below
  - (d) the following materials are permitted: unpolished Portland, Purbeck, York or Nabrasina marbles, Celtic Limestone, slate, honed pale grey granite, oak or teak. Other forms of unpolished stone may be permitted at the discretion of the Minister.
  - (e) subject to paragraph (f) below, the size of a headstone or cross and base falls within the dimensions set out in either Tables 1A and 1B or Table 2 as follow:

**Table 1A: Headstone**

	Height above Ground		Width		Thickness	
	Imperial	Metric	Imperial	Metric	Imperial	Metric
Maximum	48"	1200mm	36"	900mm	6"	150mm
Minimum	30" including base	750mm Including base	20"	500mm	3"	75mm

**Table 1B: Headstone Base**

	Height above Ground		Width		Depth	
	Imperial	Metric	Imperial	Metric	Imperial	Metric
Maximum	6"	150mm	38"	950mm	12"	300mm
Minimum	3"	75mm	22"	550mm	7"	175mm

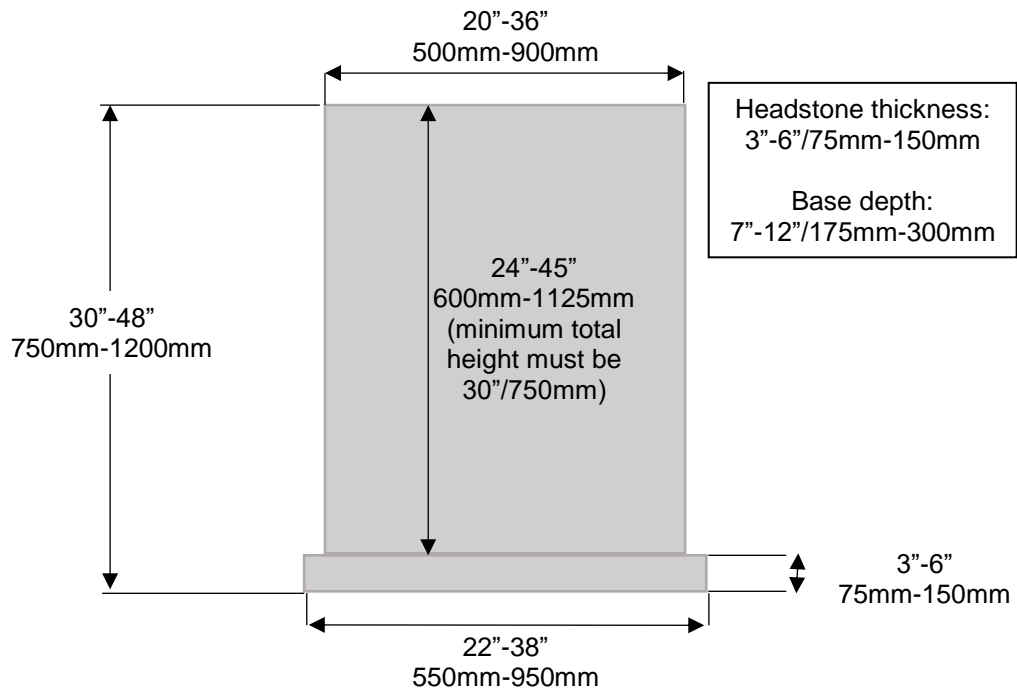

**Table 2: Cross**

	Height above Ground		Width		Thickness	
	Imperial	Metric	Imperial	Metric	Imperial	Metric
Maximum	60"	1500mm	36"	900mm	12"	300mm
Minimum	30"	750mm	N/A	N/A	3"	75mm

In the case of a timber cross the minimum thickness permitted is 1.5 inches (40mm)

- (f) a memorial for a child aged under 16 years at the date of death may be smaller than the standard sizes specified above at the discretion of the Minister.
- (g) kerbs, railings or chippings, whether raised or at ground level, are not permitted.
- (h) moulded figure work is not permitted.
- (i) the inscription on a memorial should contain the names of the deceased, the date of his or her death, and the date of birth or the age at death. All factual material in the inscription must be accurate.
- (j) the words to be inscribed on a memorial or any emblem, badge or other design, must be appropriate in the opinion of the Minister (and any necessary third party permissions obtained).
- (k) photographic reproductions are not permitted.
- (l) all words inscribed must, in the opinion of the Minister, be clearly legible and the overall layout and design set out suitably.
- (m) any infilling of lettering and other designs shall be of grey matt finish or earth colour enamel and, in the opinion of the Minister, shall be in harmony with the material from which the memorial is made.
- (n) no advertisement or trademark is permitted. If the name of the craftsman who produced the memorial is inscribed on the memorial, it shall be on its side or reverse only, in lettering similar to the main inscription and not more than 15 millimetres in height.
- (o) the anchorage of all memorials must be in accordance with the best practices of the industry and must comply with current Health and Safety Regulations.

4. This Regulation concerns the interment of ashes.
- (a) Biodegradable containers shall be used save where ashes are placed directly into the ground without a container.
  - (b) Individual memorials are only permissible in principle where the Faculty authorising the setting aside of an area for the interment of ashes so permits. In such cases the Minister may permit the marking of any individual interment by means of a tablet if the following conditions are met:
    - (i) application for the introduction of the object is made in writing to the Minister on the standard "Application under Churchyard Regulations" form, such application to be submitted to the Minister at his or her usual address *and*
    - (ii) application is made no sooner than one month after the date of the relevant interment.
  - (c) In addition to the conditions in Regulation 4(b), the following conditions concerning form, size and type of stone must be met:
    - (i) in a case where the Faculty authorising the setting aside of an area for the interment of ashes has specified the form and or size of memorials, the memorial is in the specified form and or size *or*
    - (ii) in any case where the Faculty authorising the setting aside of an area for the interment of ashes permits the placing of individual memorials but does not specify the form and size of such memorials, the memorial is to be in the form of a tablet not exceeding (21"x 21") 525 millimetres x 525 millimetres and
    - (iii) in any case where the Faculty authorising the setting aside of an area for the interment of ashes has specified any permitted stone or stones, the memorial is of a permitted stone *or*
    - (iv) in any case where the Faculty authorising the setting aside of an area for the interment of ashes permits the placing of individual memorials but does not specify the type of stone permitted, the memorial is to be of unpolished Portland, Purbeck, York or Nabrasena marbles, Celtic limestone, slate, honed pale grey granite, oak or teak, or another form of unpolished stone at the discretion of the Minister

- (d) In addition to the conditions in Regulation 4 (b) and (c), the following conditions concerning the design of memorials must be met:
- (i) the inscription should not exceed four lines of text including the names of the deceased and dates of birth and death, save that nine lines of text are permissible in the case of a double interment. All information must be accurate.
  - (ii) the words to be inscribed on a tablet and any emblem, badge or other design must be appropriate in the opinion of the Minister (and any necessary third party permissions obtained).
  - (iii) photographic reproductions are not permitted.
  - (iv) all words inscribed must, in the opinion of the Minister, be clearly legible and the overall layout and design must be set out suitably.
  - (v) any infilling of lettering and other designs shall be of grey matt finish or earth colour enamel and, in the opinion of the Minister, shall be in harmony with the material from which the memorial is made.
  - (vi) the name of any craftsman, trademark or other advertising may not appear on the tablet.

5. This Regulation concerns flower containers. The Minister may grant permission for the introduction into a churchyard of a container for flowers provided that the following conditions are met:

- (a) in the case of a flower container which is to be set in the base of a memorial, its top will not protrude above the level of the base *or*
- (b) in the case of a flower container which is to be buried in the ground immediately in front of the memorial, its top will not protrude above ground level *and*
- (c) if the flower container is to be placed in an area where there are cremated remains, a Faculty has provided for tablets to be placed over individual interments. Such a container must either be incorporated into the tablet or buried in the ground within the plot, in such a way that it will not protrude above ground level or project beyond the plot itself.

6. This regulation concerns artificial flowers. Artificial flowers may be permitted for a temporary period by the Minister. Rose bushes and other shrubs shall not be planted on individual graves.
  
7. For the purposes of these Regulations, 'Minister' means the Incumbent of the Benefice in which the churchyard is situated or, where rights of presentation are suspended, the Curate licensed to the charge of that parish or the Minister acting as Priest-in-Charge.
  
8. In the exercise of any discretion under these Regulations, the Minister shall have regard to the current version of the Churchyard Guide.

Robin Hopkins  
Commissary General of the City and Diocese of Canterbury  
January 2022